

LINEA DOMO



SINCE 2005



Upholstered Bed Product Care & Warranty

LINEA DOMO

IN PURSUIT OF PERFECTION
FURNITURE SINCE 2005

Product Care and Warranty.
Please retain this Care Book
for future reference.



PO BOX 6842
Wetherill Park
NSW 2164, Australia

T +61 2 9732 9666
F +61 2 8003 9118
lineadomo.com.au

Linea Domo – Part of
Denai Group 2024
V202403

Contents

1.0	General Care	5
1.1	The Linea Domo Story	6
1.2	Understand Your New Bed	7
1.3	Most Common Characteristics In Genuine Leathers	9
1.4	General Care Tips	10
1.5	Leather Care Tips	11
1.6	Fabric Care Tips	12
2.0	Product Warranty	13
2.1	Warranty Period	14
2.2	Manufacturer's Warranty Terms And Conditions	15
3.0	Bed Assembly Instruction	20
3.1	Assembly Instructions for bed	21
3.2	Assembly Instructions for Single And King Single Size Bed	24
3.3	Assembly Instructions for Bed With Powered Lift Up Storage	26
3.4	Assembly Instructions for Bed With Manual Lift Up Storage	35

1.0

General Care



1.1 The Linea Domo Story

Proudly designed and manufactured exclusively for the Australian homemaker using only finest componentry including top grain cowhide leather. Because this product is made in our own factory, we are able to control all facets of manufacture and supply to comply with the stringent standards set by the management of Linea Domo.

OUR LEATHER

In the manufacturing of the complete Linea Domo product range, only top-grain cowhide leather is used on the finished Product. No split leather is used. Furthermore, the leather has passed tests of both Australian and European standards for colour fastness and rub testing for durability, as well as chemical tests to ensure it is safe and friendly for both your family and our environment.

OUR RANGE

Our broad upholstery product range includes Classic and Contemporary beds and accessories. One outstanding feature of the collection for our customer is the ability to adapt ranges to fulfill your needs. Each product is custom made to your selected colour and combination and it is unique to you.

QUALITY CONTROL

Believing in the delivery of quality is the culture of our organization; elaborate steps are undertaken at each and every stage of the manufacturing process to deliver an end product which is as perfect as it can be. Quality Control starts with the receipt of all raw materials whether it is timber, foam, steel, fibre, fabric or leather and continues till the end with packing and dispatch.

OUR SERVICE

When you buy a Linea Domo product, we will ensure that you receive a quality product. Should your product need servicing for any reason, our nation wide service team is there to ensure your satisfaction.

We are dedicated to the complete process of manufacturing to the needs of our customers, and while we are constantly striving to become the best Manufacturer of quality furniture at a realistic price to the local market, we will always have a global vision. We are convinced our dedication will result in your satisfaction for many years to come.

1.2 Understand Your New Bed

We want to make sure your bed arrives to you in the best possible condition and so we package it well to protect it on its journey to your home. During the journey, a few crush marks may appear on your bed but please do not be alarmed, these will naturally work their way out over a few weeks.

If your new Linea Domo bed feels or looks a little different to the one you saw in the store (the headboard may feel firmer; the leather may look tighter), that's because your furniture is brand new, unlike the store's floor sample which may have already been well 'run-in' by many visitors. Like a new pair of shoes, or a saddle, with regular use your new furniture will also gradually begin to adapt to your expectations.

WHAT TO EXPECT WITH USE

An advantage to bear in mind is that a fine bed doesn't wear out, it wears in. This also means that your bed can (and will) relax into a more casual appearance over time. When pressure is applied to the polyurethane foam for the first time, the micro cells within the foam structure break which creates a slight softening effect. This natural cellular breakdown is expected. It also means that during the first few weeks of use comfort creases and wrinkles will form naturally in the leather. These characteristics give it a soft inviting look that is an inherent feature of the best leather upholstery.

THE BEAUTY OF GENUINE LEATHER

Your Linea Domo product features unique and hand made signatures that individually personalise every design. Just as no two fingerprints are alike, each piece of leather is distinctive in its markings. These markings add beauty to the leather and serve as proof of its authenticity. Leather is a natural material, so every hide has unique characteristics; and as our furniture is made from many hides, the leather may show slight colour and grain variation-this is only natural.

Age adds character and reflects how leather furniture has been used during its lifetime. Over the years, leather adapts itself to the user and develops its own personal look.

With regular use, as the leather fibres relax, we expect that comfort creases may form in the areas that receive the most body contact. All these signs serve as more evidence of the leather's authenticity and should be no cause for concern.

VILLA AND PREMIUM LEATHER RANGE

These are corrected grain leather made from quality top-grain cowhides. They may have shown marks, scars, insect bites, nicks etc. which are natural characteristics of genuine leather.

The impact of these irregularities is reduced by lightly buffing and pigmentation. Then a uniform grain pattern is embossed to restore a beautiful, even look. These ranges are perfect for everyday living and require less maintenance.

SCOTLAND LEATHER

Scotland leather is semi-aniline leather made from high-quality cowhides. The top is slightly treated and then finished with wax protection. This range is soft and supple to the touch and will develop a distressed look and patina with use. This style is for people who prefer a vintage and natural leather look.

Due to its unique characteristics, this leather requires a little more maintenance. To help extend the life of this beautiful product, it should be lightly cleaned with a dry, clean cloth on a regular basis.

Please refer to page 11 for leather care tips.

1.3 Most Common Characteristics In Genuine Leather

As a natural product, good quality leather will have different markings—a guarantee of being genuine and what makes your Linea Domo upholstery unique. Some other examples of the characteristics you can expect to see with leather upholstery are:

Vein lines

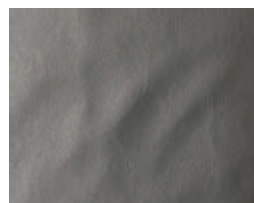

Grain variation

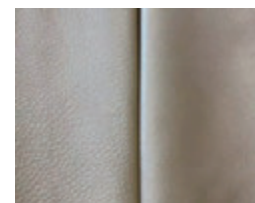

Colour variation

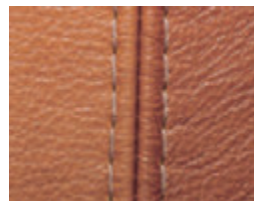

Skin blemishes



DESIRED EFFECT
Oiled and waxed leather will develop a patina after a very short period of usage. That is a desired effect of this type of leather as shown below.

Stretching

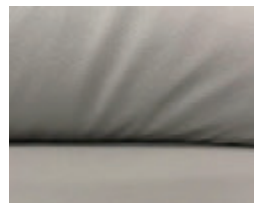

Horn butts, scrapes & scars



Fat Wrinkles

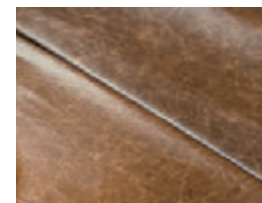
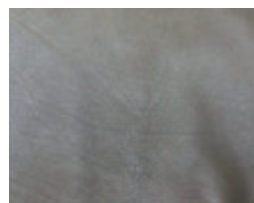

1.4 General Care Tips

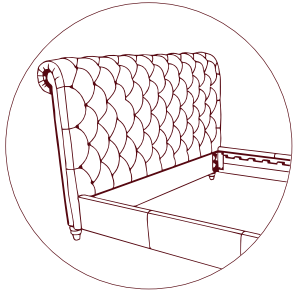

During the first 3 months, foam padding will become softer. Light creases may form on the cover following this. This is to be considered as normal wear.

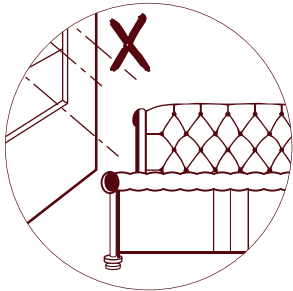

To avoid your Linea Domo upholstery fading, it is best not to expose it to direct sunlight.

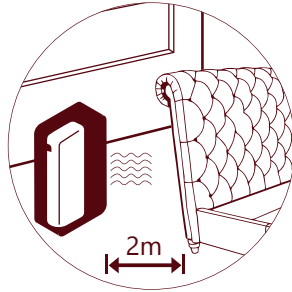

Your Linea Domo upholstery should be placed at least 2 meters away from any heat source.



If you have pets, please be careful with them around your product. Pets can damage your product through chew marks, claws and oil residue from their fur all of which are not covered within our warranty terms.

1.5 Leather Care Tips

A regular routine of protection and cleaning will not only help protect your furniture from stains and damage, but it will also add years to its life. Some types of soiling only affect the way your furniture looks; others can actually damage the leather. Dust and perspiration are both particularly damaging. Dust is abrasive: it acts like sandpaper. Over time dust can cause serious damage to the furniture's topcoat.

Perspiration and body oils contain salts, enzymes and fatty acids, all of which can stain and damage leather and its topcoat. It is important to prevent perspiration and body oils from building up. Particular care needs to be taken if you regularly take medications, as they can increase the damage caused by perspiration and body oils.

- Clean the leather regularly with a soft damp white, colour-fast cloth to remove grease, dirt and dust.
- To remove dry stains, sweep them off carefully with a clean hand or with an extremely soft brush.
- To remove liquid stains, blot the surface by dabbing carefully with a paper towel, do not press hard, as this could push the stain into the pores of the leather.
- DO NOT use soap, saddle soaps, oils, all-purpose cleaners, detergents, solvents, spray cleaners or abrasive cleaners on your leather furniture.
- DO NOT dry the leather in direct sunlight or with a hair dryer.

ADDITIONAL CARE TIPS FOR SCOTLAND LEATHER

Besides the above General Leather Care Tips, Scotland Leather with a wax finish will occasionally need to be revitalised if your furniture is starting to look scratched, scuffed or faded; then it is time to revitalise.

- Wipe contact areas with a clean damp cloth regularly.
- Clean with an approved Mild Leather cleaner 3-4 times per year.
- Apply an approved pullup leather rejuvenation cream when needed.
- Following cleaning or the application of rejuvenation cream, protection cream should be reapplied.
- Remove spills immediately to avoid staining.

Sharp items can easily scratch the surface of the leather; this will add to the distressed appearance yet can be mostly remedied with the application of a speciality revitalising cream.

Your Harvey Norman Sales Team Member can advise the correct products to maintain your purchase.

1.6 Fabric Care Tips

- Vacuum regularly with an upholstery attachment, using low suction.
- Spot clean where necessary.
- Treat spills and stains as soon as possible. Gently remove any soil or mop any liquid from the surface of the fabric. Do not saturate the fabric or filling with water or any other cleaning fluids. Seek professional advice from a fabric cleaning specialist.

Pilling can occasionally occur as a result of normal daily wear and should not be considered a fault. It can be successfully and easily removed with a battery-operated pilling tool available from most haberdashery stores. "De-pilling" only removes unsightly surface fibres, does not affect fabric performance, and is generally permanent.

A SPECIAL NOTE ON LEATHER AND FABRICS

The leather/fabric warranties in this booklet do not apply where there is evidence of excessive soiling, improper cleaning, or abuse or where the leather/fabric has had a chemical treatment applied by the retail dealer or consumer which has not previously been approved in writing by Linea Domo. Please do not move furniture by pulling on leather or fabric.

Medications: If leather furniture is used constantly by individuals on some medications (including, but not limited to, chemotherapy, blood pressure and heart medications), extra care should be taken to protect leather surfaces from direct skin contact as the chemistry in these medications may react with and damage the leather finish. Headrest covers and arm protectors are advisable.

2.0

Product Warranty

2.1 Warranty Details

WARRANTY PERIOD

Subject to terms and conditions on pages 14-19.

1. FRAME WARRANTY

The internal frame construction (including webbing and springs) of Linea Domo upholstery furniture is covered against manufacturing and material defects for ten (10) years. This is provided that the defect is not a result of normal wear and tear, or a natural characteristic of the material used.

2. LEATHER WARRANTY

The leather upholstery of Linea Domo products is covered against splitting and tearing due to manufacturing and material defects for a period of two (2) years. This is provided that the defect is not a result of normal wear and tear, or a natural characteristic of the material used.

3. FABRIC WARRANTY

The fabric upholstery of Linea Domo products is covered against manufacturing and material defects for a period of one (1) year. This is provided that the defect is not a result of normal wear and tear, or a natural characteristic of the material used.

4. COMPONENT AND WORKMANSHIP WARRANTY

Workmanship (stitching, staples, legs, zipper, dust cover, calico, studs etc.) of Linea Domo upholstery are covered against defects for a period of one (1) year.

5. ELECTRICAL PART WARRANTY

Any electrical part used in Linea Domo products is covered against defect for a period of one (1) year, which includes electrical/lift chair motor, Transformer, remote control, touch buttons, lights, smart cup holders, voice controls, USB ports etc.

6. FOAM WARRANTY

Foam used in Linea Domo upholstered bed is covered against material or manufacturing defects for a period of ten (10) years. Softening of foam should be expected as a result of normal use and is not to be confused with loss of resilience.

2.2 Manufacturer's Warranty Terms And Conditions

The following terms and conditions relate to the purchase of our furniture products (Product) manufactured by us (Jinao International Holding (Australia) Pty Ltd ACN 107 665 387 trading as Linea Domo of Unit A 120 Hassall St, Wetherill Park NSW 2164) and purchased by you.

1. STATUTORY GUARANTEES AND RIGHTS

Our goods come with guarantees that cannot be excluded under the Australian Consumer Law (ACL). You are entitled to a replacement or refund for a major failure and compensation for any other reasonably foreseeable loss or damage. You are also entitled to have the goods repaired or replaced if the goods fail to be of acceptable quality and the failure does not amount to a major failure.

In addition to the rights and remedies set out in this Manufacturer's Warranty, you are entitled to bring an action directly against us as manufacturer of the product for damages in the circumstances set out in the ACL. This Manufacturer's Warranty is not intended in any way to limit or exclude such rights and remedies that you may have under law.

2. MANUFACTURER'S WARRANTY

Our Manufacturer's Warranty:

- is not intended to change or exclude any statutory consumer rights that cannot be lawfully changed or excluded;
- is independent of any warranty that may be provided by the seller, for which it carries sole responsibility; and
- does not affect your rights against the seller, including any mandatory statutory rights you may have against the seller under the ACL.

All other conditions and warranties expressed or implied are hereby excluded. No other person or persons (including our employees) are authorised by us to offer or give on our behalf any other or greater warranty than that given by us under this Manufacturer's Warranty.

In addition to any other rights that you may have under the ACL, we offer you a Manufacturer's Warranty on the following terms and conditions:

- a. we warrant that the product will be free from defects in workmanship and materials;
- b. the warranty above applies for the warranty periods set out on page 14 of this booklet from the original delivery date of the product (Warranty Period), regardless of whether a replacement has been provided under this warranty during the Warranty Period;

- c. if the product fails during normal and proper use within the Warranty Period, we will repair or replace the defective parts of the product, or the product itself, with new parts or products that are functionally equivalent or superior to those originally supplied; and
- d. all components or products repaired or replaced by us will be under warranty for the remaining period of the Warranty Period.

The decision whether to repair or replace a product under this Manufacturer's Warranty is at our sole discretion.

This Manufacturer's Warranty is not transferable and applies to the original purchaser only. The Manufacturer's Warranty is voided if the Product is resold or transferred or given to a new owner.

3. WHEN THE MANUFACTURER'S WARRANTY WON'T APPLY

Our products are intended for domestic or household use only and this Manufacturer's Warranty does not cover damage arising from use of the product in a commercial, rental trade, institutional or other non-residential environment.

This Manufacturer's Warranty also does not apply to customer induced damages or circumstances outside our control including, but not limited to:

- a. any damage caused by transporting the product including by you, the seller, its contractor, our contractors or any other person;
- b. damage or discoloration to the product caused by accident, fire, water damage, scratching, spills such as acid solvents and dyes or other corrosive materials, ink, paint or "bodily fluids", newsprint transfer or fabric dye, exposure to excessive heat, moisture or dampness, contamination with vermin or insects, transference of perspiration, body oils or the corrosive ingredients contained in personal care products such as hair gels and skin creams;
- c. the normal and expected settling of soft filling such as polyester fibre and leather;
- d. damage or degradation of leather or fabric coverings not properly maintained (i.e. the regular removal of dust and dirt by appropriate means and the application of endorsed cleaning and leather nourishing products as instructed at the time of sale);

- e. leather grain variation, colour variation, wrinkling, markings and scars resulting from the natural features of the hide;
- f. natural settlement of foam due to normal wear and tear;
- g. failure to maintain feather fillas advised by us resulting in compacted fill;
- h. damage to the product resulting from repair work carried out by persons other than our authorised contractors or from the use of other than our genuine spare parts;
- i. damage caused from the use of the product in a manner other than the use for which it was specifically designed;
- j. damage caused by normal wear and tear, including scratches, dents, chips, marks accidental breakages;
- k. damage arising from failure to use and care for the product in a fit and proper fashion according to our instructions as set out in this booklet or as labelled on the product (including damage due to the application of chemicals, cleaners or conditions not endorsed by us);
- l. damage to the product caused by war, terrorism, fire, accident, natural disaster, intentional or accidental misuse, abuse, neglect, improper maintenance or use under abnormal conditions;

- m. damage to the product as a result of excessive use of cleaning products or cleaning agents;
- n. fraud, theft, unexplained disappearance or wilful act; or
- o. any other event, act, default or omission outside our control.

Our Manufacturer's Warranty will not be valid if (i) if you transport the product to an area outside Australia or (ii) if you do not have clear proof of purchase.

4. TRANSPORTATION OF PRODUCT AND OTHER EXPENSES

Once you have made your claim, we will either:

- a. send out an authorised contractor or repairer to assess your claim and/or to repair the product and/or to collect the product (depending on the situation); or
- b. arrange for the product to be transported back to our warehouse.

You must allow our authorised contractor or retailer to assess the product or our contractor to pick the product for transportation within 7 days of our confirmation that we will assess your claim.

If your claim is not approved, or if you live a remote area or outside a metropolitan area or the product is to be picked up from a location not easily accessible at our discretion, you will be required to pay the travel / labour / inspection / transportation costs which will have been disclosed to you prior to our assessment.

If a claim is not approved, you can request that we make repairs to the product. Any such services will be provided subject to separate terms and conditions between us and you and for a fee to be determined prior to the repairs being done.

5. HOW TO CLAIM UNDER THE MANUFACTURER'S WARRANTY

To make a claim under this Manufacturer's Warranty, you must contact the seller of your product within 7 calendar days after the defect or damage appears in the product and prior to the expiry of the applicable Warranty Period.

You must provide the following information upon notification of the defect:

- a. your name;
- b. your phone number;
- c. copy of your proof of purchase;
- d. product details;
- e. details of the defect claimed; and
- f. any other details the seller requires.

Once we have received a notification of defect from the seller, we will determine whether your warranty claim is a claim we will assess, and if it is, we will inform you of how we will make the assessment, and if approved, how we will honour it. We may require further information in order to assess your warranty claim which you will provide without delay. Any decision on a warranty claim will be at our sole discretion.

You can contact us by telephone on (02) 9732 9666 or by email at service@denai.com.au

6. MISCELLANEOUS

- a. The products are hand made products. The size of each individual piece may vary from the sample or any product specifications quoted. For the same reason, the comfort and subjective feel of the goods may vary slightly from product to product. These variations are considered normal and in no way will affect the wear ability of the product.
- b. Natural characteristics of the good/s cannot be deemed as a defect (see booklet). Scars, marks and differing pore density and colour are natural characteristics of leather and are not considered defects. Leather may vary in colour and texture from the original sample as it is a natural product.
- c. Fabrics, leathers, suspension components, cushioning and fillings will show signs of wear and tear with use. Fabrics and leathers will fade and crease. Foam and fillings will soften and form to the shape of the user over time. Depending on the covering and the degree of use, the covering materials, cushion fillings and suspension may need to be replaced periodically at the customer's expense.
- d. Foam is a product that compresses with use. We consider this to be normal wear and tear. The comfort of seating

is subjective and is very hard to gauge the degree of firmness or softness. Softening of foam should be expected as a result of normal use and is not to be confused with loss of resilience.

- e. Colour matching orders are taken on the strict understanding that exact matching cannot be guaranteed to be a precise match due to the variations in the natural products used in the manufacture of these goods.

3.0

Bed Assembly Instruction

Quick Tip:

You may view Linea Domo Power Lift bed assembly video on our website under 'Resource' section:

www.lineadomo.com.au



3.1 Assembly Instructions for bed

Step 1. Assemble Bed Legs

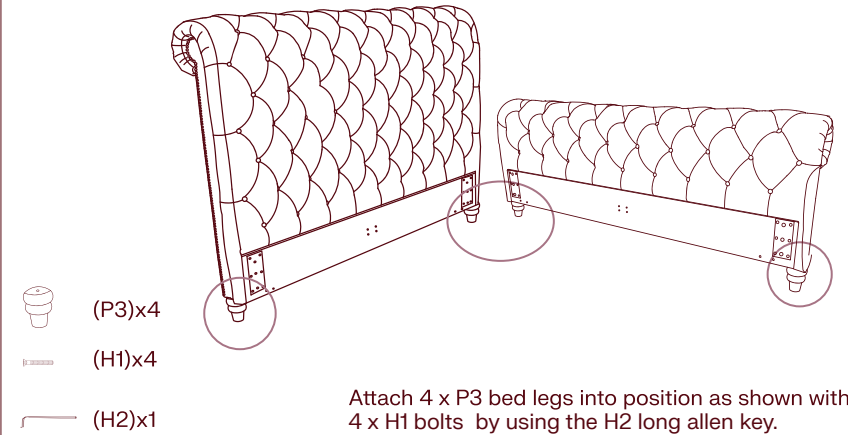

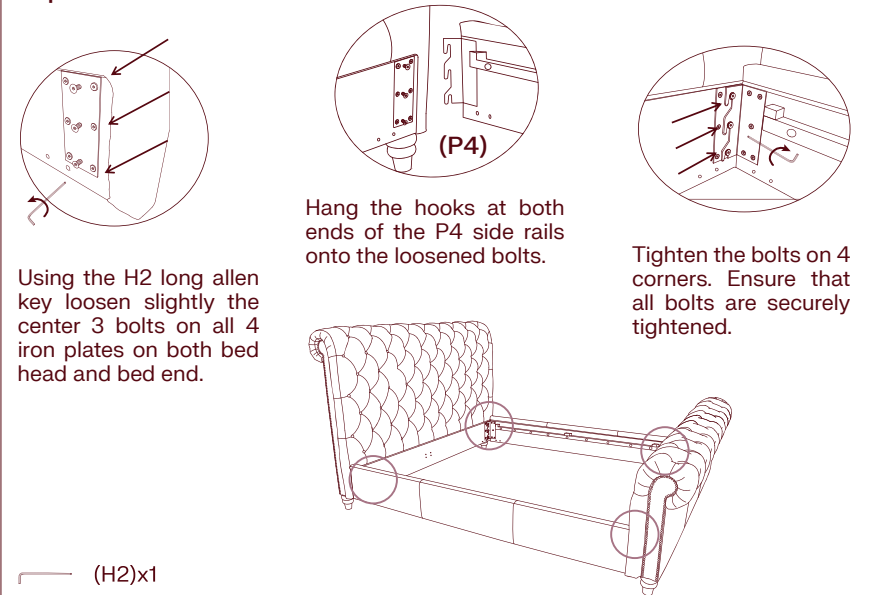

Step 2. Assemble Side Rails

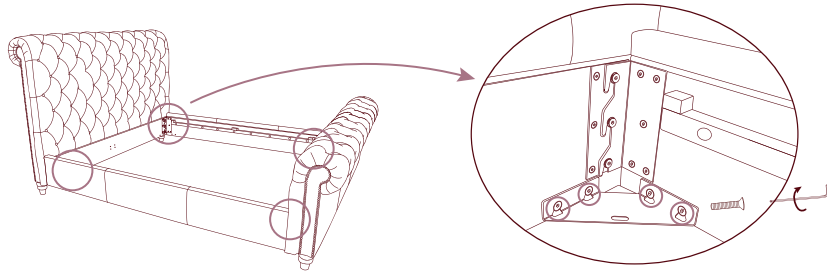

Step 3. Assemble The Corner Support Brackets





-  (H3)x4
-  (H4)x16
-  (H2)x1

Attach the 4 x H3 corner support brackets onto 4 corners of bed as shown with the 4 x H4 bolts by using the H2 long allen key.

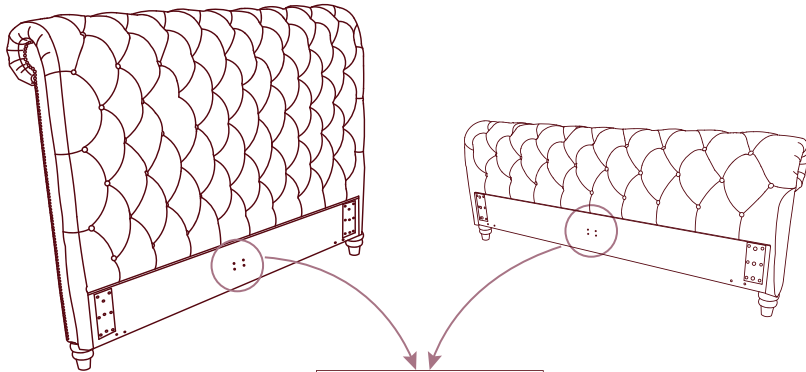
Step 4. Assemble The L Shape Brackets





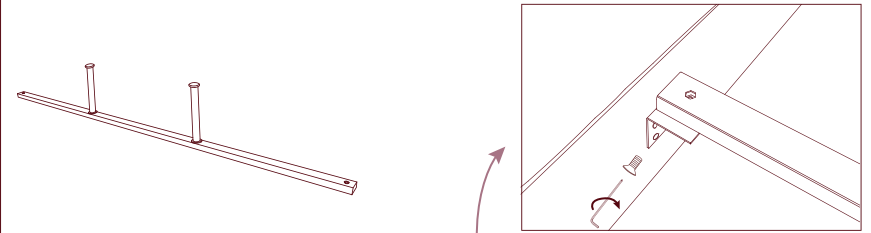

-  (H5)x2
-  (H6)x8
-  (H8)x1

Attach the H5 L shape brackets into position as shown on bed head and bed end with 4 x H6 bolts by using the H8 allen key.

Step 5. Assemble Support Leg And Center Rod



Attach 2 x H7 support legs into position as shown on P5 center rod.

-  (H7)x2
-  (H9)x2
-  (H2)x1
-  (P5)x1

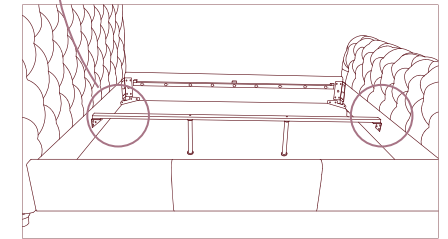

Secure both ends of the center rod with the H9 bolt by using the H2 long allen key.

Step 6. Place Bed Slats Onto Bed

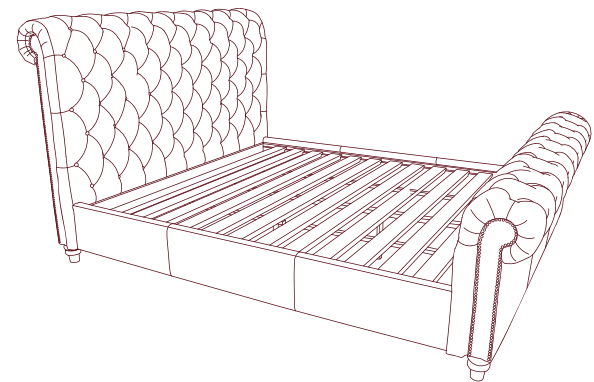

-  (P6)x2

Finally along the bed side notch, place two P6 bed slats onto bed as shown.

3.2 Assembly Instructions for Single And King Single Size Bed

Step 1. Assemble Bed Legs

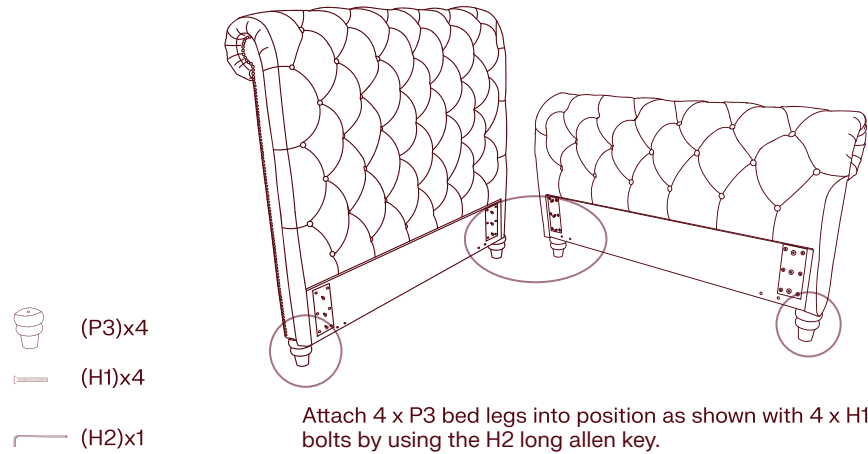

Step 2. Assemble Side Rails

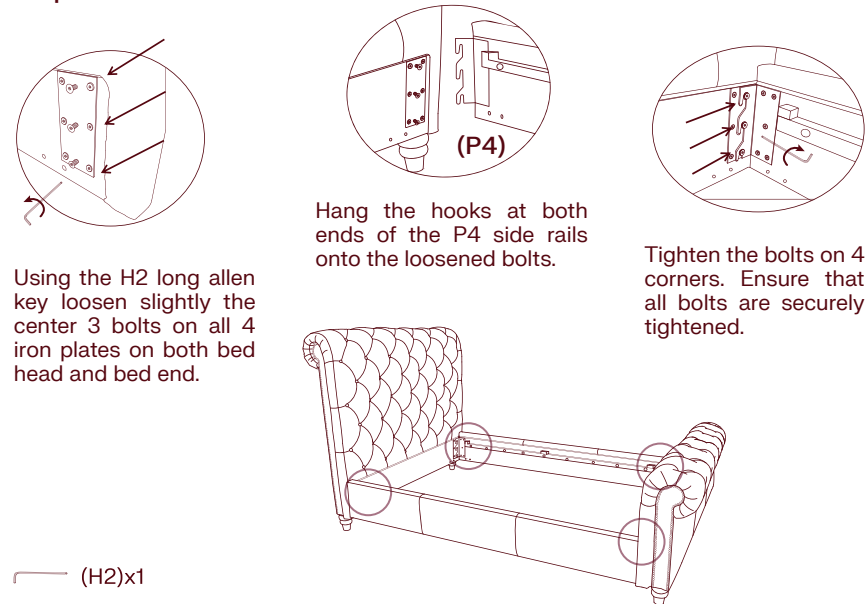

Step 3. Assemble The Corner Support Brackets

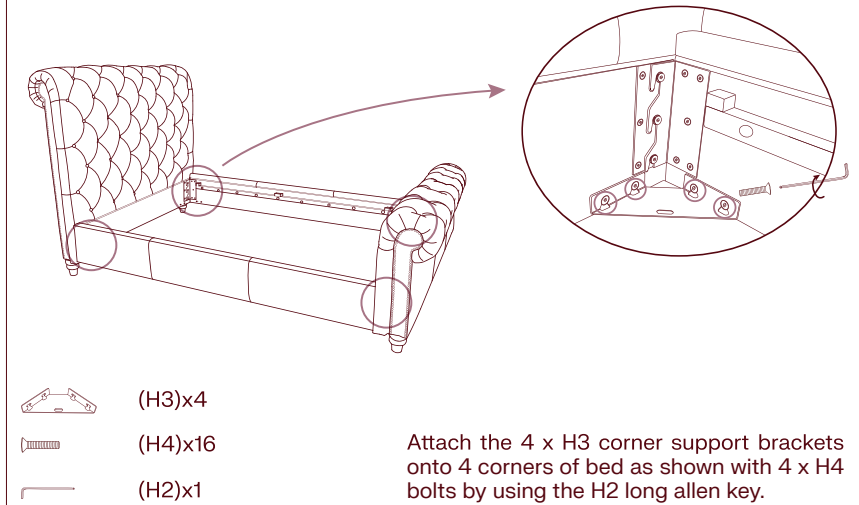

Step 4. Place Bed Slats Onto Bed



3.3 Assembly Instructions for Bed With Powered Lift Up Storage

Safety Warning

This appliance is not intended for use by persons (including children) with reduced physical, sensory or mental capabilities, or lack of experience and knowledge, unless they have been given supervision or instruction concerning use of the appliance by a person responsible for their safety. Children should be supervised to ensure that they do not play with the appliance.

Assembly Instructions

Step 1. Assemble Bed Legs

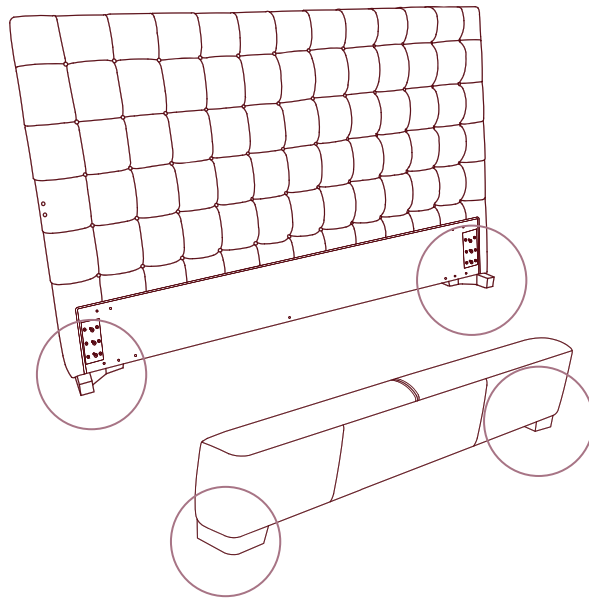

(P3)x4



(H1)x8



(H9)x1

Attach 4 x P3 bed legs into position as shown with 8 x H1 bolts by using the H9 long allen key.

Step 2. Assemble Side Rails

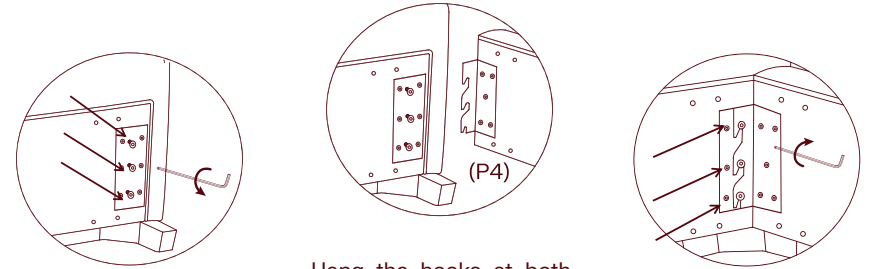

Using the H9 long allen key loosen the existing 3 bolts on 4 iron plates between bed head and bed end.

Hang the hooks at both ends of the P4 side rails onto the loosened bolts.

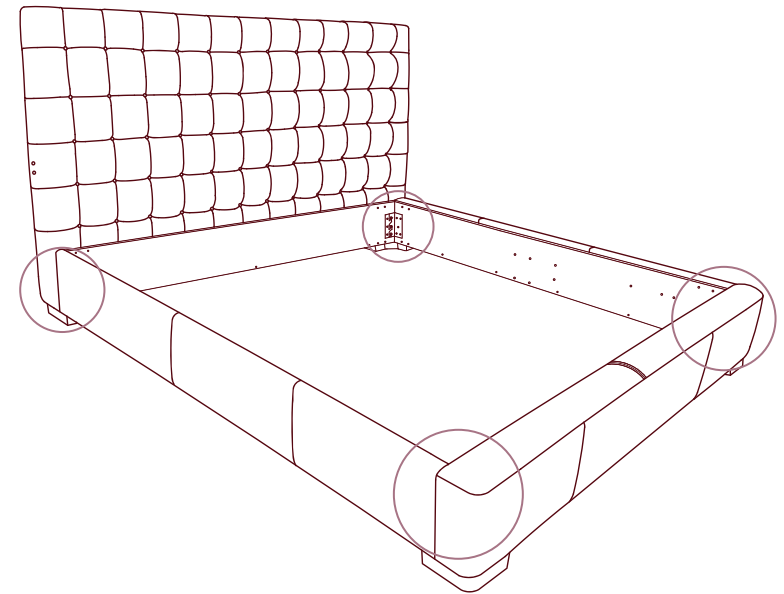

Tighten the bolts on 4 corners. Ensure that all bolts are securely tightened.

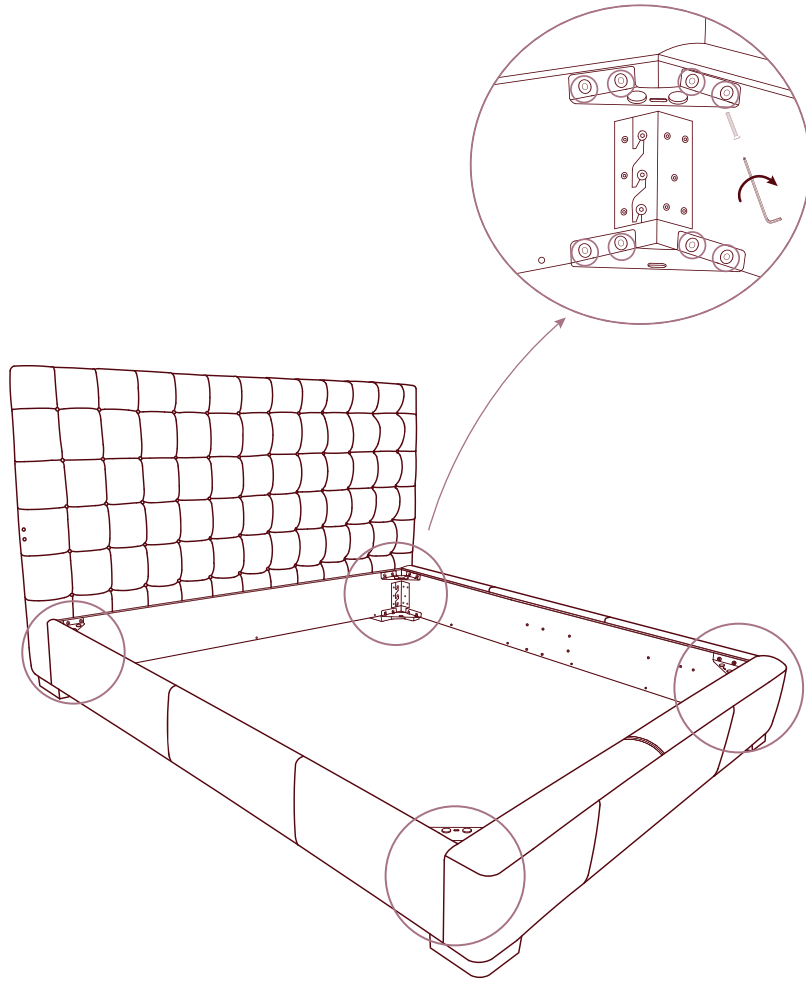

(H9)x1

Step 3. Assemble The Corner Support Brackets



-  (H11)x8
-  (H2)x32
-  (H9)x1

Attach the 8 x H11 corner support brackets onto 4 corners of bed as shown with 32 x H2 bolts by using the H9 long allen key. Each corner will be attached with two corner support brackets, one on top side and another on bottom. (Please place the corner support brackets with felts on the top side)

Step 4. Assemble Bed Lift Mechanism Plate-Left And Right

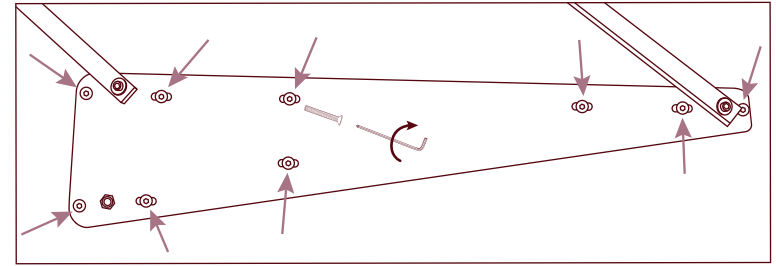

Attach the two P5 lift brackets onto each bed side with 18pcs(9pcs on each side) H2 bolts by using the H9 long allen key. The narrow end is pointed towards the bed end.

-  (H2)x18
-  (H9)x1

Step 5. Assemble The Electric Motor

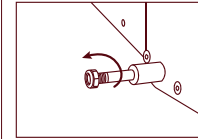

(5.1) Unscrew this bolt on the main frame.

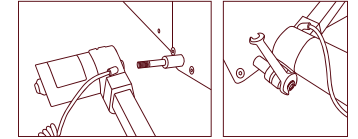

(5.2) Insert the motor body into this bolt and tighten nut.

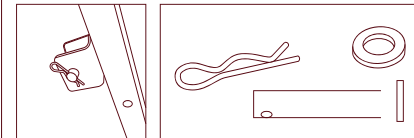

(5.3) Undo and release this arm from the main body by removing the pin and bolt. Put aside.

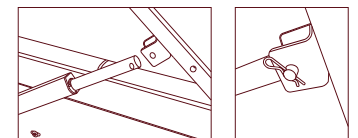

(5.4) Pull the piston arm to meet the bracket and re-insert the bolt, the washer and secure with the nut.

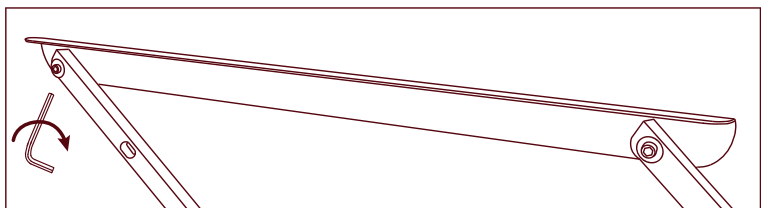

(5.5) Tighten the screw on the P7 electric motor support bar with the H14 allen key.

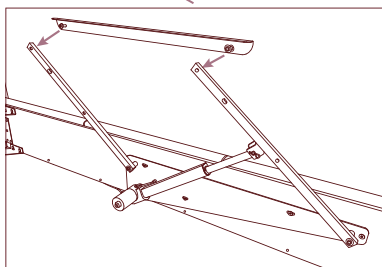

 (H13)x1  (H14)x1

Connecting wire part is ok

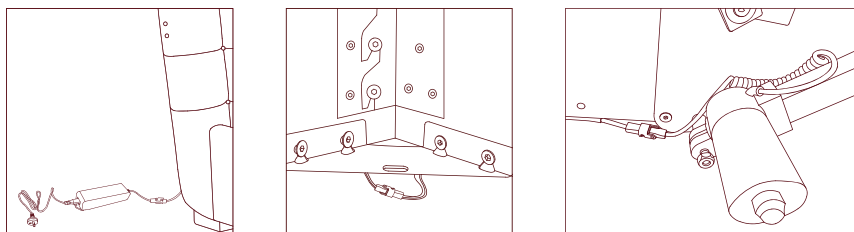

Connect the power cord set to the connecting wire under the bed head, side rail and motor.

Step 6. Prepare Bed Base Braces 4 x Long and 2 x Short

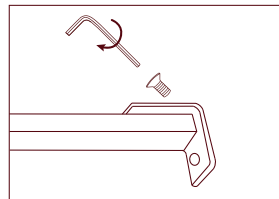

4 x Long

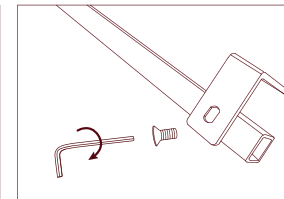



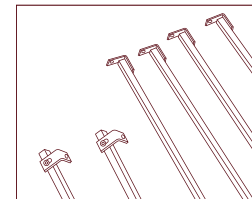

2 x Short

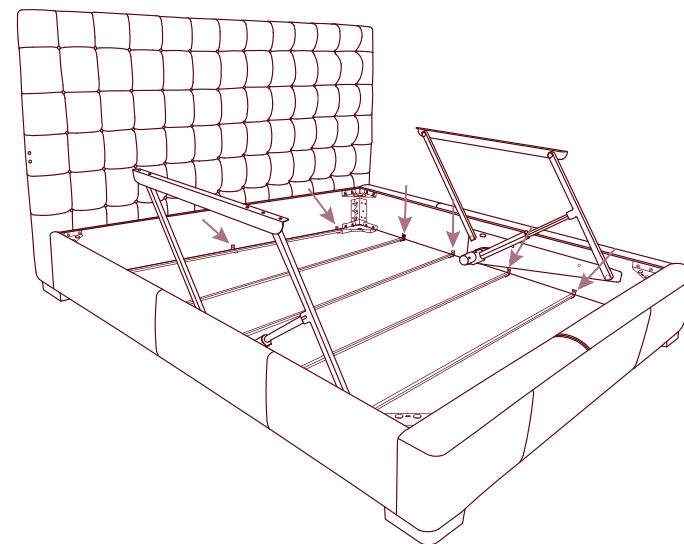

Connect the H12 L brackets to the P12 Bed Base Braces according to Long and Short positions using the H4 bolts.





 (H10)x1
 (H4)x14
 (H3)x14
 (H12)x14

Install the 2 x Short Braces on either end of the bed and the 4 x Long Braces in the middle using the H3 bolts.

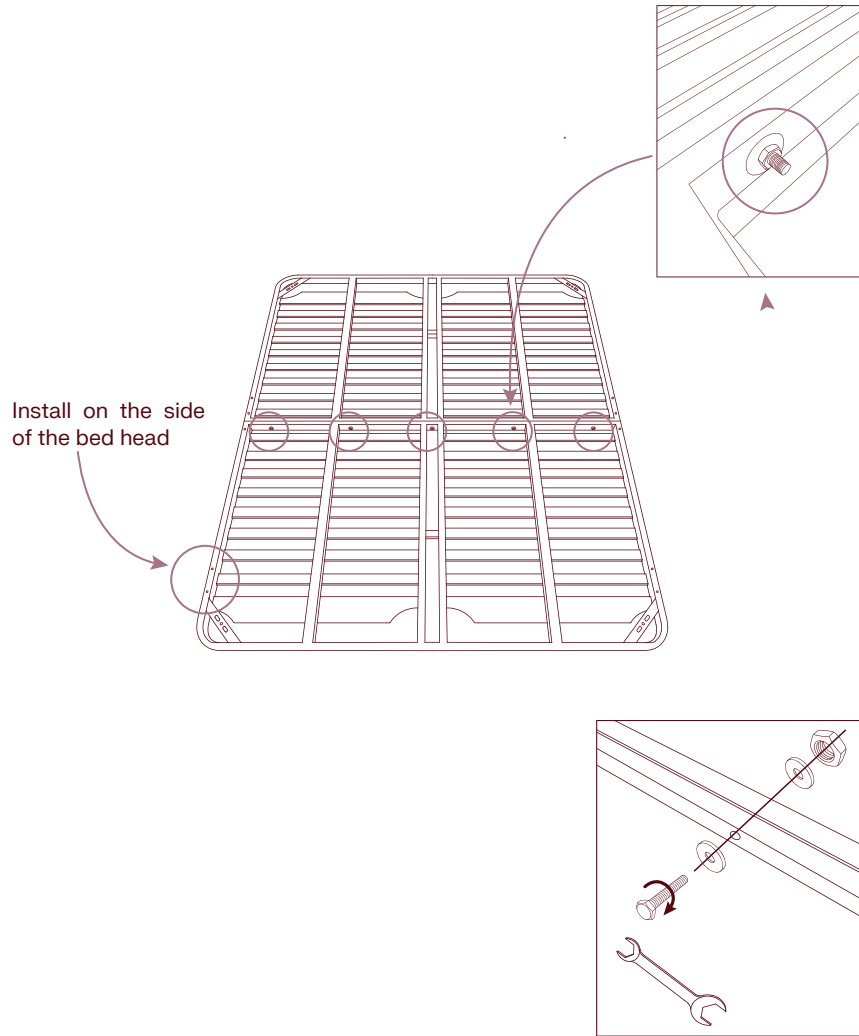
Step 7. Assemble Bed Slats





-  (H6)x5
-  (H7)x10
-  (H8)x5
-  (H13)x1

Assemble the two P10 bed slats sets together with the H6 bolt & 2 x H7 flat washers by using the H13 wrench to tighten the H8 screw nut as shown.

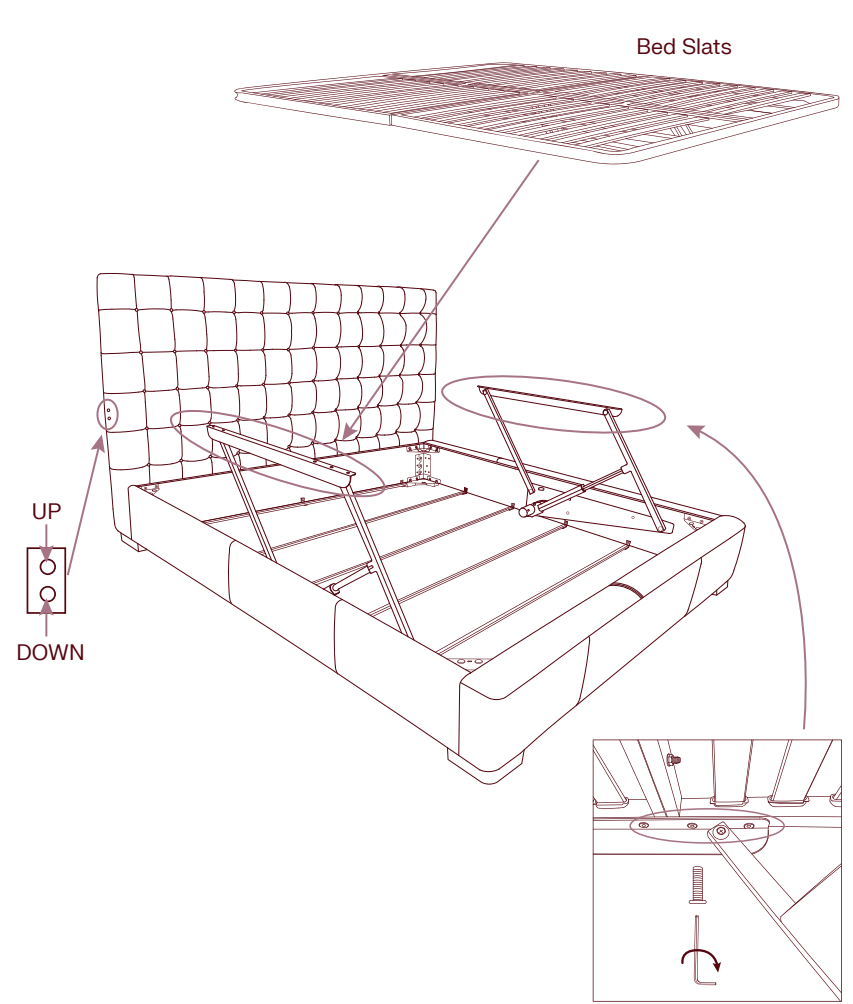
Step 8. Assemble Bed Slats And Electric Motor Support Bars Together



-  (H5)x10
-  (H9)x1

Press the UP/DOWN button to raise the P5 lift mechanism to the top. Position the bed slat to the two P7 support bars and secure with the 5 x H5 bolts on each side using the H9 long allen key provided.

Step 9. Assemble Bed Base Storage Panels

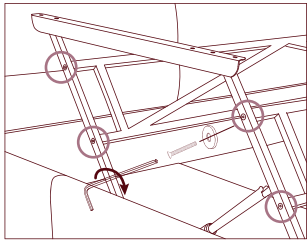

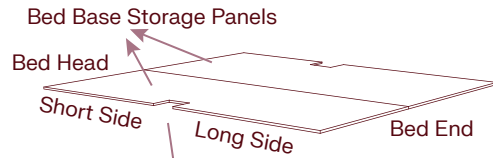

Attach two P11 stabilising braces to the middle of the P7 electric motor support bars with H2 bolts and 1pc H7 flat washer by using the H9 long allen key as shown (four pcs for each side).

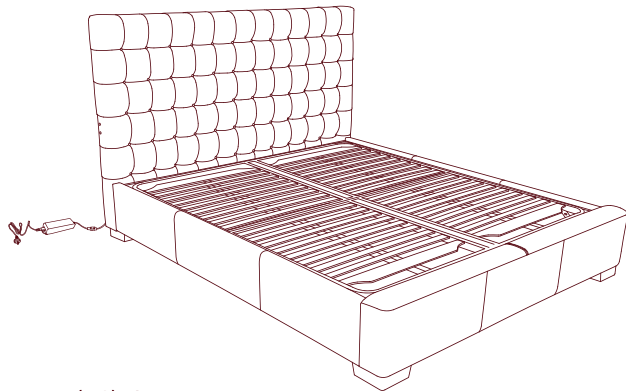
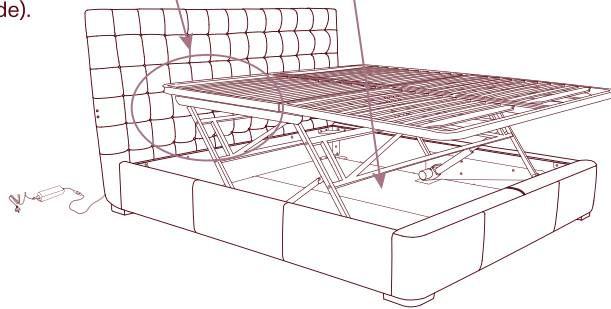

Place the P12 bed base storage panels on the bottom of the bed frame, with the narrow end pointing towards the bed head.



-  (H2)x8
-  (H9)x1
-  (H7)x8

Once the slats are in position and secured, press the DOWN button to return the bed back into original position.

3.4 Assembly Instructions for Bed With Manual Lift Up Storage



Safety Warning

This appliance is not intended for use by persons (including children) with reduced physical, sensory or mental capabilities, or lack of experience and knowledge, unless they have been given supervision or instruction concerning use of the appliance by a person responsible for their safety. Children should be supervised to ensure that they do not play with the appliance.

Assembly Instructions

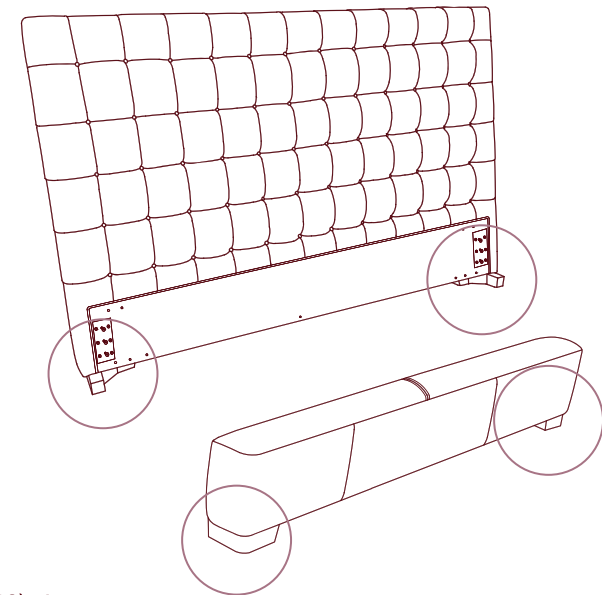
Step 1. Assemble Bed Legs



-  (P3)x4
-  (H1)x8
-  (H9)x1

Attach 4 x P3 bed legs into position as shown with 8 x H1 bolts by using the H9 long allen key.

Step 2. Assemble Side Rails

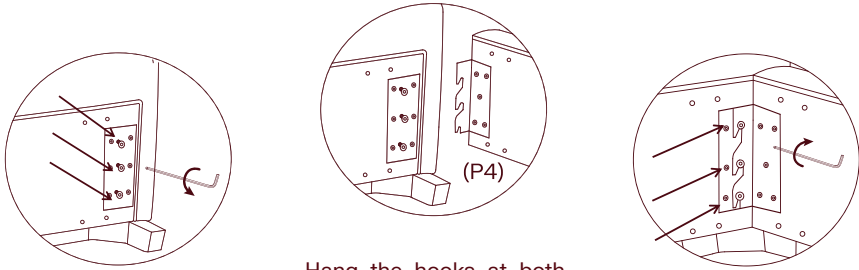

Using the H9 long allen key loosen the existing 3 bolts on 4 iron plates between bed head and bed end.

Hang the hooks at both ends of the P4 side rails onto the loosened bolts.

Tighten the bolts on 4 corners. Ensure that all bolts are securely tightened.

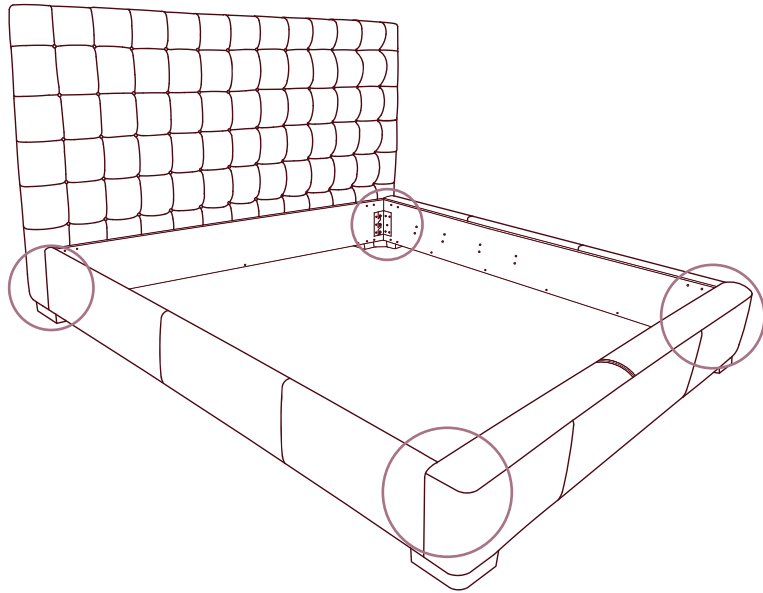

 (H9)x1

Step 3. Assemble The Corner Support Brackets

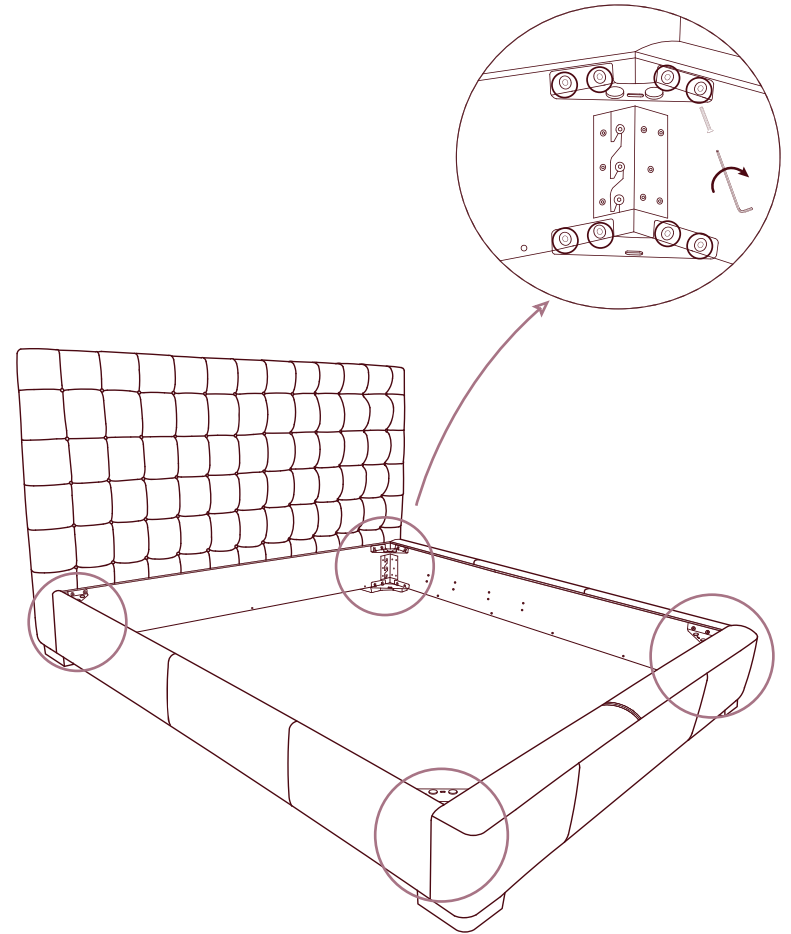

 (H11)x8

 (H2)x32

 (H9)x1

Attach the 8 x H11 corner support brackets onto 4 corners of bed as shown with 32 x H2 bolts by using the H9 long allen key. Each corner will be attached with two corner support brackets, one on top side and another on bottom. (Please place the corner support brackets with felts on the top side)

Step 4. Assemble Bed Lift Mechanism Plate–Left And Right

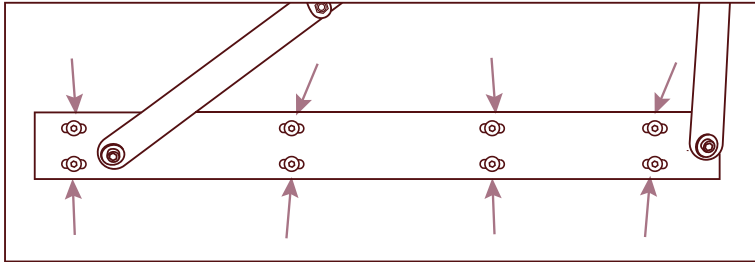

Attach the two P5 support bar onto each bed side with 16pcs(8pcs on each side) H2 bolts by using the H9 long allen key.

 (H2)x16  (H9)x1

Step 5. Tighten support bar

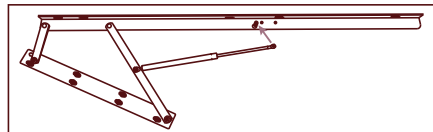
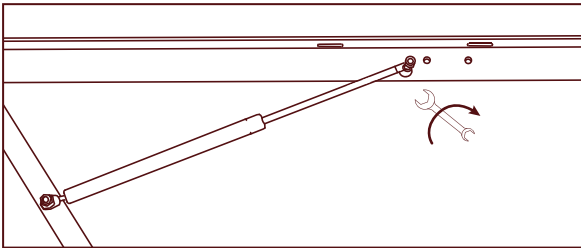

 (H13)x1 Tighten the screw on the P5 support bar with the H13 wrench.

Step 6. Prepare Bed Base Braces 4 x Long and 2 x Short

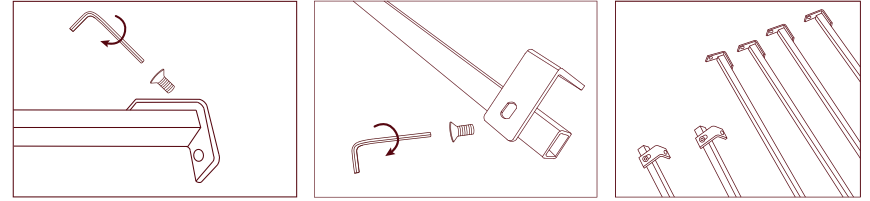

4 x Long

2 x Short

Connect the H12 L brackets to the Bed Base Braces according to Long and Short positions using the H4 bolts.

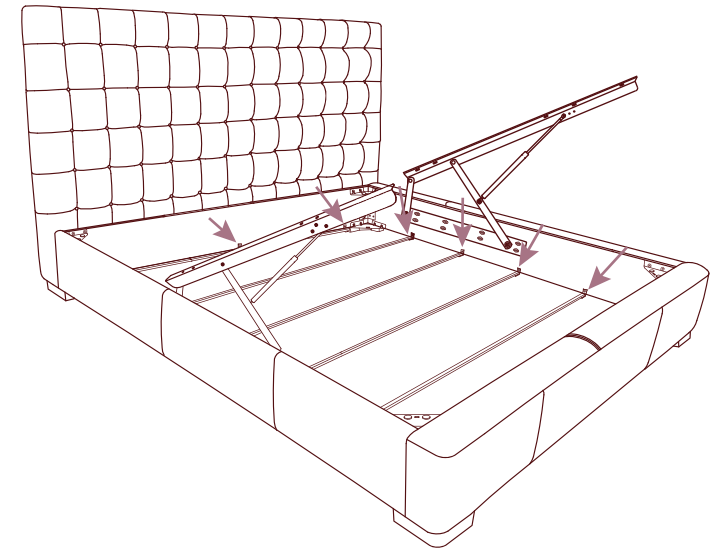





 (H10)x1
 (H4)x14
 (H3)x14
 (H12)x14

Install the 2 x Short Braces on either end of the bed and the 4 x Long Braces in the middle using the H3 bolts.

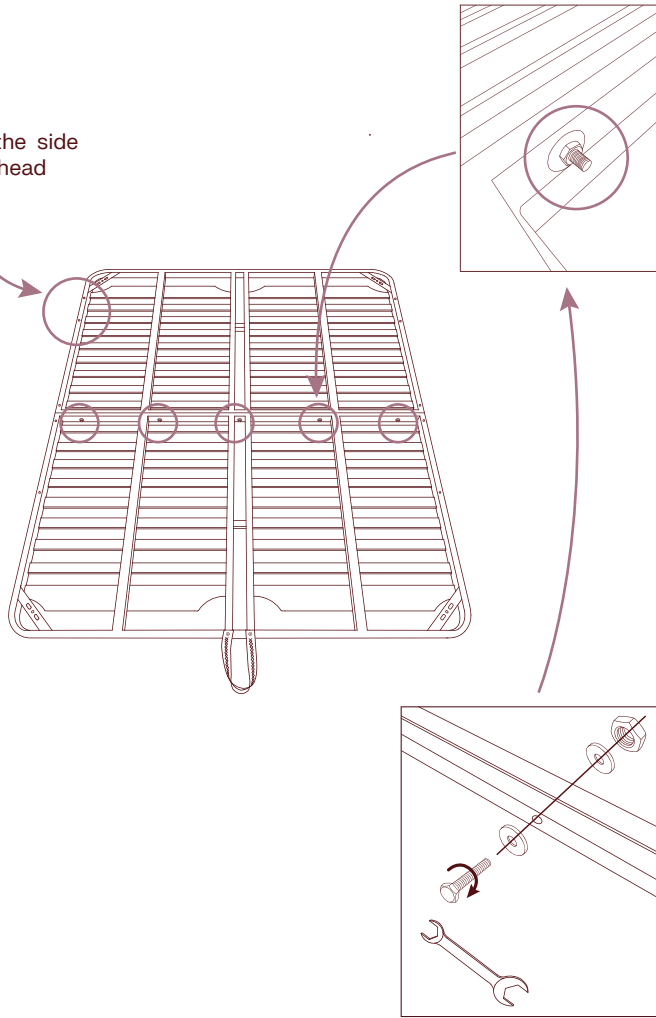
Step 7. Assemble Bed Slats

Install on the side of the bed head





-  (H6)x5
-  (H7)x10
-  (H8)x5
-  (H13)x1

Assemble the two P8 bed slats sets together with the H6 bolt & 2 x H7 flat washers by using the H13 wrench to tighten the H8 screw nut as shown.

Step 8. Assemble Bed Slats And Support Bars Together

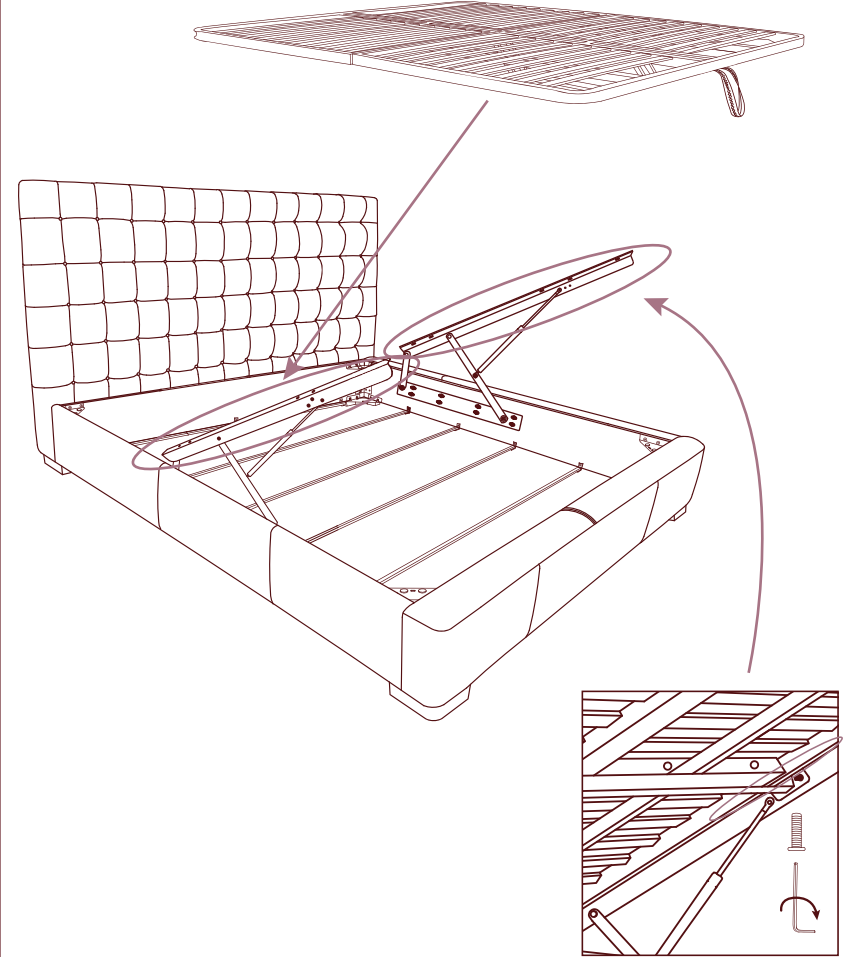
Bed Slats



-  (H5)x10
-  (H9)x1

Position the bed slat to the two P5 support bars and secure with the 5 x H5 bolts on each side using the H9 long allen key provided.

Step 9. Assemble Bed Base Storage Panels

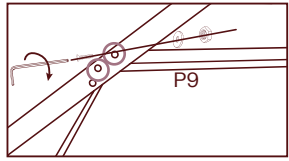

Attach one P9 stabilising brace to the middle of the P8 Bed slats with H14 bolts, 1pc H7 flat washer and the H8 screw nut by using the H9 long allen key as shown (two pcs for each side).

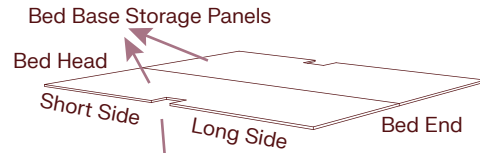

Place the P11 bed base storage panels on the bottom of the bed frame, with the narrow end pointing towards the bed head.

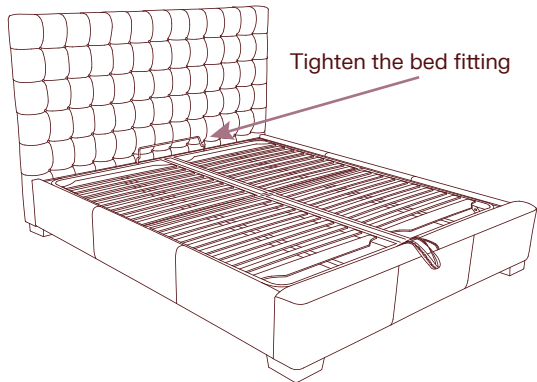
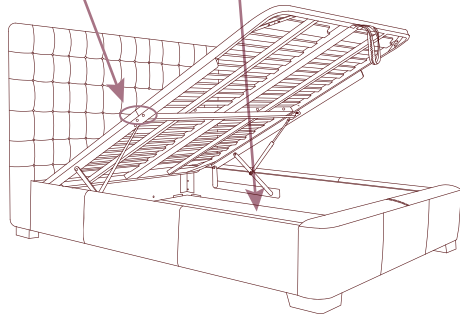

Once the slats are in position and secured.



- (H8)x4
- (H14)x4
- (H9)x1
- (H7)x4

Proudly Australian Owned.

Made with care. Made to last.